

STORY WALL NOTES:

1. INSTALL MURAL FIRST. SURROUNDING PANELS MUST BE REVERSE HUNG. REFER TO MANUFACTURER INSTALLATION INSTRUCTIONS PROVIDED WITH ORDER.
2. TOP AND BOTTOM OF CIRCLE MAY CUT OFF.
3. SCOOP AND SPATULA SHOULD APPEAR ON STORY WALL IN FULL.
4. OUTER CIRCLE WILL WRAP TO BACK OF WALL.
5. INSTALL ACRYLIC FRAME WITH NON-GLARE ACRYLIC FACING OUT.

GENERAL NOTES:

1. ALL ARTWORK IS OWNER PROVIDED, GC INSTALLED
2. ARTWORK COMES WITH SECURITY HARDWARE
3. BOTTOM OF ARTWORK SHOULD BE INSTALLED 6" ABOVE THE TOP OF WAHNSCOTING

1 ELEV. - STORY WALL
A-7 SCALE: 1/4" = 1'-0"

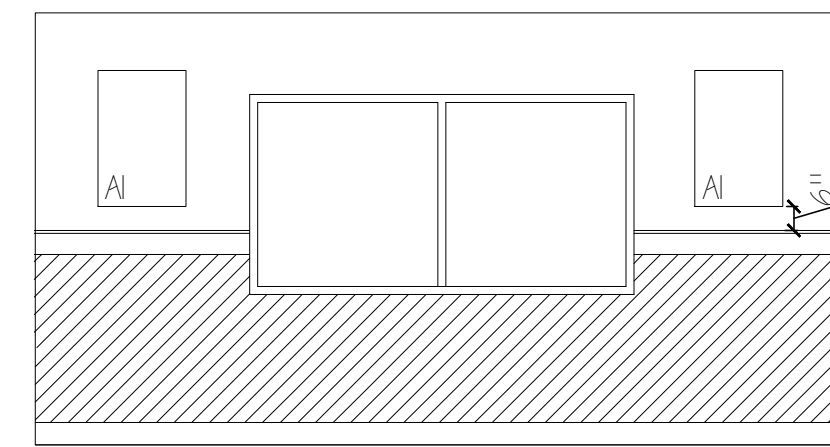

2 ELEV. - CANVAS ART TYP.
A-7 SCALE: 1/4" = 1'-0"

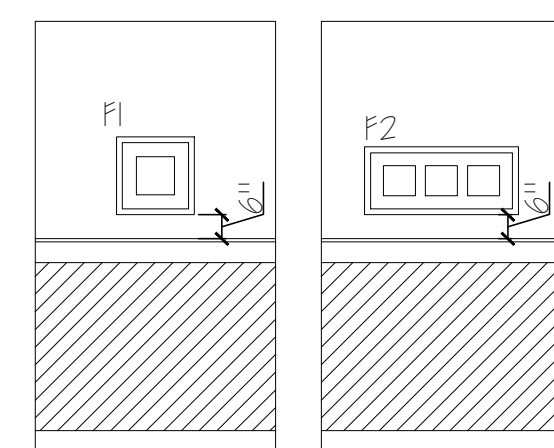

3 ELEV. - FRAMED ART TYP.
A-7 SCALE: 1/4" = 1'-0"

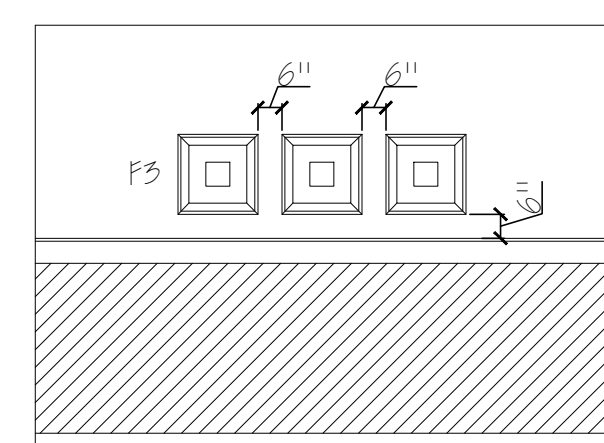

4 ELEV. - F3 FRAMED ART TYP.
A-7 SCALE: 1/4" = 1'-0"

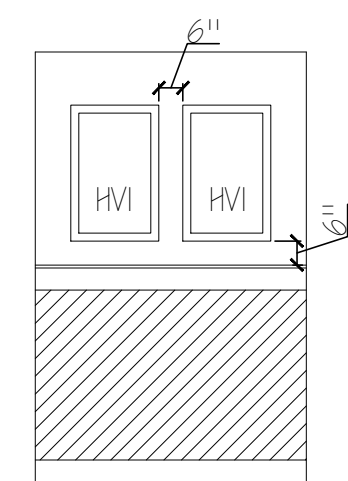

5 ELEV. - HEART OF FRESHNESS ART TYP.
A-7 SCALE: 1/4" = 1'-0"

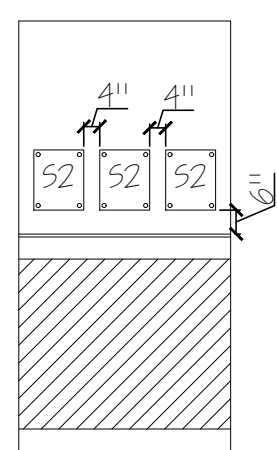

7 ELEV. - LAYERS OF DELICIOUS FUN TYP.
A-7 SCALE: 1/4" = 1'-0"

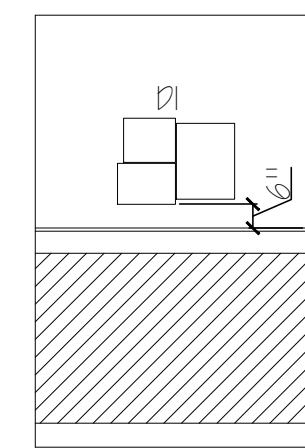

6 ELEV. - DELICIOUS ON SO MANY LEVELS TYP.
A-7 SCALE: 1/4" = 1'-0"

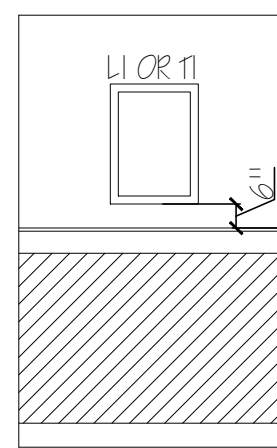

8 ELEV. - CULVER'S PRIDE: STATE ART OR TRAVEL POSTER TYP.
A-7 SCALE: 1/4" = 1'-0"

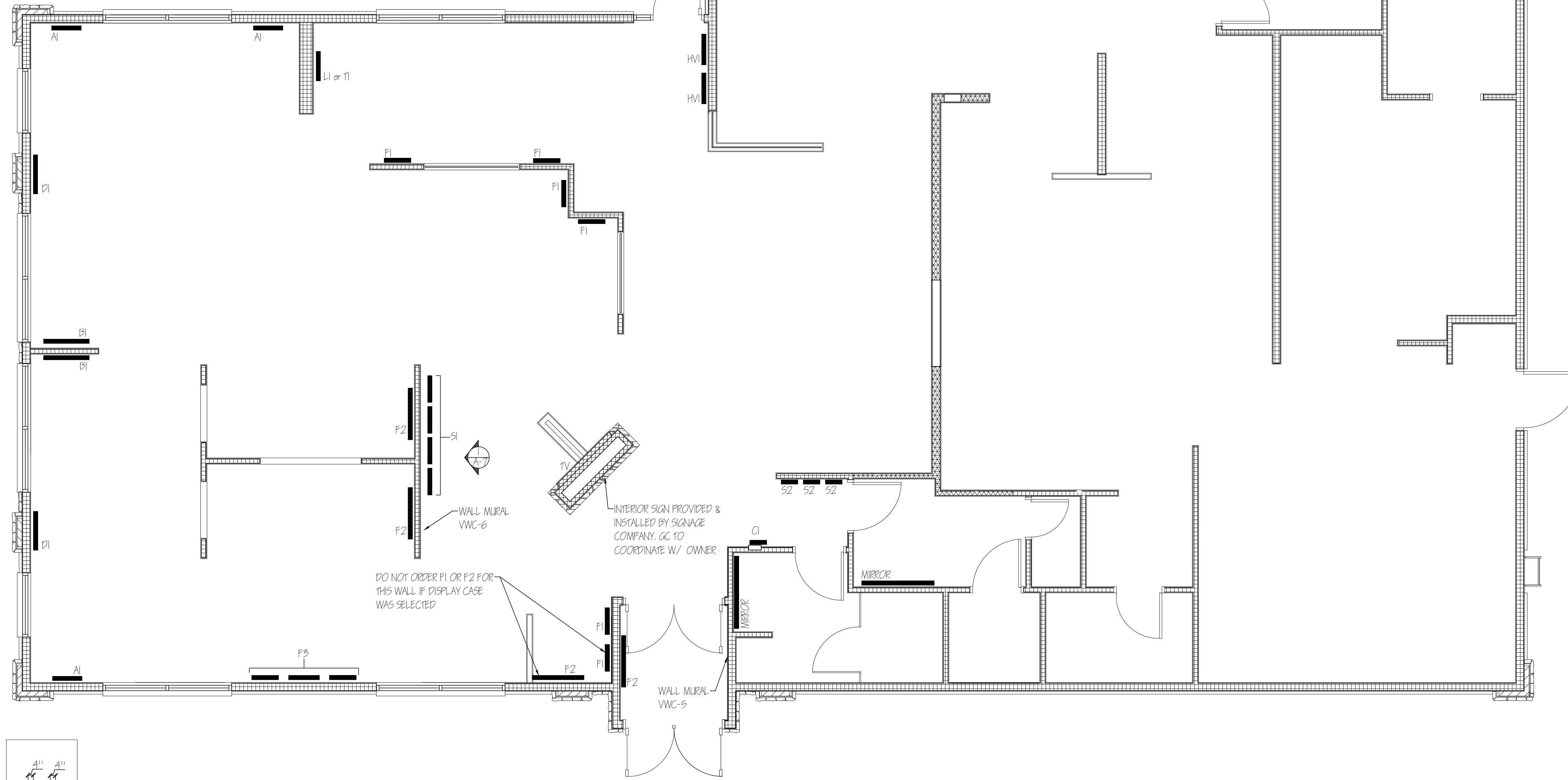

INTERIOR DECOR SCHEDULE				
TYPE	SIZE (WIDTH X HEIGHT)	QUANTITY	COLLECTION	TYPE
AI	22 X 34	3	VERTICAL CANVAS	CANVAS GALLERY WRAPPED
BI	34 X 22	2	HORIZONTAL CANVAS	CANVAS GALLERY WRAPPED
DI	13 X 11, 14.5 X 10.25, 14.5 X 19	2	DELICIOUS ON SO MANY LEVELS	PRINTED METAL 3-PIECE COLLAGE
FI	19.5 X 19.5	6*	FRAMED	FRAMED AND MATTED PRINTS, NON-GLARE ACRYLIC
F2	38.5 X 20	4*	FRAMED	FRAMED AND MATTED PRINTS, NON-GLARE ACRYLIC
F3	(3) 19.5 X 19.5	1	FRAMED	FRAMED AND MATTED PRINTS, NON-GLARE ACRYLIC
HVI	22 X 34	2	VERTICAL HEART OF FRESHNESS	WOOD FRAME W/ PRINTED PVC INSERTS
SI	20 X 24	4	STORY WALL	ACRYLIC FRAME W/ METAL STAND OFFS
S2	12.5 X 15	3	LAYERS OF DELICIOUS FUN	ACRYLIC FRAME W/ METAL STAND OFFS
LI	22 X 30	1*	CULVER'S PRIDE: STATE ART	FRAMED AND MATTED PRINT, NON-GLARE ACRYLIC
TI	22X30	1*	TRAVEL POSTER	FRAMED AND MATTED PRINT, NON-GLARE ACRYLIC
CI	12.5 X 15	1	GUEST COMMUNICATIONS	ACRYLIC FRAME W/ METAL STAND OFFS
MIRROR	34 X 36	2	RESTROOM MIRRORS	LAMINATED COMPOSITE FRAME

*ACTUAL NUMBER OF PIECES NEEDED MAY DIFFER PER SPECIFIC LOCATION AND PLAN. SEE PACKAGE B LIST FOR VENDOR CONTACT INFORMATION.

INTERIOR DECOR PLAN - METRO L - 2025 PROTOTYPE
SCALE: 1/4" = 1'-0"

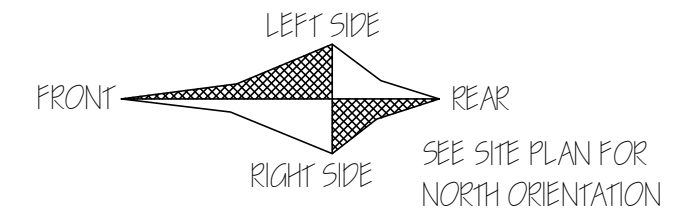

WARNING: These plans are for the exclusive use of Culver Franchising System, LLC and authorized franchise holders only. No part of these plans or the design they represent may be duplicated or reproduced without permission of Culver Franchising System, LLC.

By	
Date	
Revision	

Culver Franchising System, LLC
1240 Water Street
Prairie du Sac, WI 53578
608-643-7980

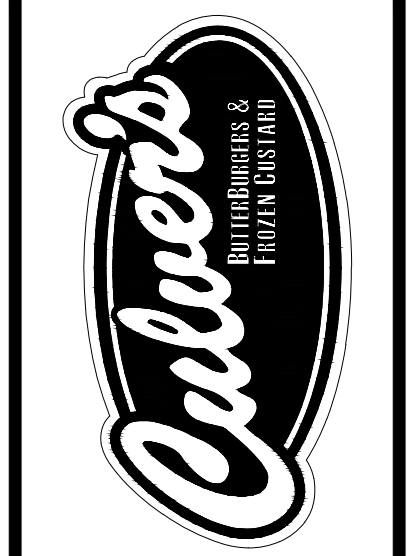

CULVER FRANCHISING SYSTEM, LLC
METRO L - 2025
PROTOTYPE PLANS

Sheet Contents:
INTERIOR DECOR PLAN & DETAILS
Project No. Metro L - 2025
Drawn By: S. Datka
Date: Jan. 1, 2025